



Castellari

FENIX V2

ELECTRIC RAKE

USER MANUAL AND MAINTENANCE

The language manual is available on the www.castellarisrl.com

Use and maintenance manual: www.castellarisrl.com

Manuale de uso y mantenimiento: www.castellarisrl.com



MANUFACTURE OF USE AND MAINTENANCE : www.castellarisrl.com

1.2 Subjects to whom the manual is addressed	4
1.3 Intended and unforeseen uses of the machine	4
1.4 Protections and safety devices	4
1.5 Risks arising from the use of the machine	8
1.5.1 Noise risk	8
1.5.2 Vibration risk	8
1.6 Fenix L-C V2 Components	6
2. SAFETY AND PREVENTION	10
2.1. Safety signals (pictograms)	10
2.2. Safety in use and maintenance	11
2.2.1. Safety in use.....	11
2.2.2. Maintenance safety	11
2.3. Ecology and pollution	12
2.3.1 Waste management	12
2.3.2. User Policy	12
3. Use	13
3.1 Handling and transport	13
3.2 Before use	13
3.3 connection	13
3.4 Use of the machine	13
4 MAINTENANCE AND CLEANING	14
4.1 Routine maintenance	14
4.2 Comb assembly and disassembly	14
4.3 Set-aside	14
4.4 Disposal of the machine	15
4.6 Spare parts	15
5 WARRANTY CONDITIONS	15
5.1 Exclusion from warranty	15
6 DECLARATION OF CONFORMITY	15

DESCRIPTION OF THE GENERAL CHARACTERISTICS OF THE MACHINE

1.1 Purpose of the manual

This manual collects the necessary instructions for a correct and safe use of the electric rake collect olives "Fenix L-C V2", hereafter also defined as "machine", made by Castellari S.r.l., of Imola (BO).

Before using the machine it is important to read and carefully follow the instructions indicated in this manual as compliance with the indications given, together with proper maintenance, depends on the smooth operation and durability of the machine itself.

NB: This manual is an integral part of the machine, it must always accompany it in any movement or resale. It is recommended to keep it in a safe place of which all possible users must be informed.

Machine identification

The machine is equipped with an identification plate on which the following data are given:

Name of manufacturer and full address;

Product name;

Indication of PPE to be used;

Indication of danger.

"CE" mark and year of production are printed directly on the tool.

Machine description and technical data

Fenix V2 is a machine designed to make it easier and easier to harvest olives in complete respect of the plant. The shape and movement of the teeth of the rake are in fact such as to prevent violent mechanical stresses that could damage the plant.

The fall of the fruits occurs by the slight shaking caused by the movement of the comb. The motorization group with the reduction gears is positioned at the bottom of the machine.

The operating head is located at the end of an extendable telescopic rod that allows the head with the comb to reach the foliage of the trees on which to collect the fruits.

The telescopic maneuvering rod is equipped with a quick locking system for easy and fast adjustment of the appropriate working length. The machine is equipped with a 15-meter extension cable at the ends of which two pliers are fixed for connection to the power battery.

TECHNICAL DATA:

Power supply, direct current

Voltage 12 Volts

Length 1.8 – 2.3 m 2.3 – 3.3 m

Weight 2.44 kg

Power cable length 15 m

Frequency revolutions 1100/min.

Engine power 80 Watts

Recommended battery 60-80 Ah based on usage

1.2 Subjects to whom the manual is addressed

This manual is the indispensable guide for all users who, in various ways, can use or take care of the machine in carrying out different tasks. Here are the possible professional profiles:

user:

Person, entity or company that buys or rents the machine and intends to use it for the purpose- His is the responsibility of the machine and the training of those who work around it.

operator:

Person trained to use the machine.

It is able to conduct the machine through the use of the controls arranged on the push button, it can intervene only to make simple adjustments. It is not allowed to perform maintenance on the electrical or mechanical system of the machine.

Mechanical maintainer:

Specialized technician able to intervene on mechanical organs and transmissions to carry out all the necessary maintenance and repairs. It is not allowed to carry out electrical maintenance on the machine.

Electric maintainer:

Specialized technician able to operate in the presence of voltage inside electrical panels or derivation boxes. It is not allowed to perform maintenance on mechanical parts.

1.3 Intended and unforeseen uses of the machine

The machine is intended to be used exclusively for harvesting olives by vibration.

It is intended for professional use. Operators must be eligible and be able to read and understand what is stated in this manual. The machine should be used taking into account the current rules on accident prevention, the conditions of use and the characteristics of the machine itself.



Danger:

Be careful not to use the machine in environments with an explosive atmosphere!

1.4 Protections and safety devices

The machine is equipped with safety devices to protect the operator from all moving parts of the same.

Protective Carter: A fixed device that prevents direct contact with moving organs or dangerous parts of the machine. The protection can only be removed through the use of special tools.

When the machine is in operation, the protective crankcase must be properly mounted.

Electrical interruption device: Allows the immediate interruption of all functions of the machine in case of an anomaly of the same.

The intervention of this protection emergency stop of the machine. In order for it to be reactivated, it is necessary to restore the device that caused the shutdown (fuse).

1.2 Risks arising from the use of the machine

1.2.1 Noise risk

The sound level was detected by measuring the emission with machine in motion in accordance with THE UNI EN ISO 11201 : 2010 regulations. The following values have been collected:



- Average sound pressure LpA (A) dB 76.49

The values found conclude that the operation of the machine involves a high level of noise.



During the use of the machine it is therefore mandatory to use otoprotectors such as headphones or earplugs, to avoid the onset of damage to the hearing apparatus over time.

1.2.2 Vibration risk

The vibration level was measured with the machine in motion in accordance with THE UNI EN ISO 5349-2 : 2015 regulations for the evaluation of vibrations transmitted to the MANO-BRACCIO system.

The following value has been collected:

Hand-arm vibration level: 13.10 m/s² considering an average 15-minute usage time over an 8-hour working day.

It is advisable to evaluate according to local laws the possible use of DPIdi use the tool in combination with appropriate PPE.

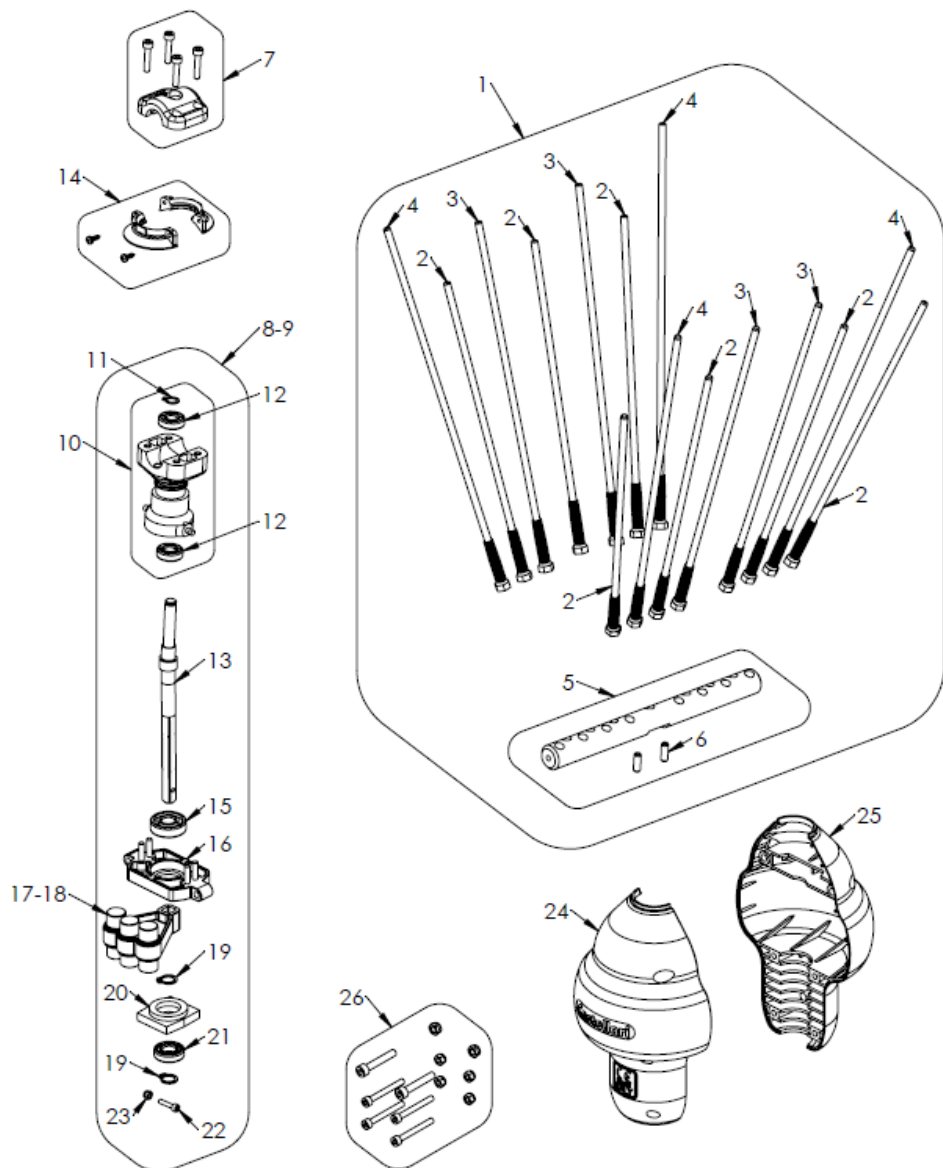

FENIX L/C V2			
POS.	SET CODE	SET DESCRIPTION	PACK
1	FX100310	FENIX COMB SET	1
2	FX100320	SHORT FENIX CARBON ROD	1
3	FX100321	MEDIUM FENIX CARBON ROD	1
4	FX100322	LONG FENIX CARBON ROD	1
5	FX100135	FENIX COMB ROD SUPPORT SET	1
6	FX100306	5X14 ELASTIC PLUG	1
7	TO700230	COMBS LOCK SET	1
8	FX100330	SHORT FENIX HEAD SET	1
9	FX100340	FENIX LONG HEAD SET	1
10	TO800209	ROTOR SET	1
11	SGR8	SEEGER Ø8	1
12	TO700130	BEARING 698ZZ	1
13	FX100210	TRANSMISSION SHAFT	1
14	TO700265	DUST PROTECTION SET	1
15	TO700175	BEARING 6000-2Z	1
16	FX100200	PLATE WITH PLUGS	1
17	FX100220	FENIX SHORT COUNTERWEIGHT	1
18	FX100222	FENIX LONG COUNTERWEIGHT	1
19	TO700110	SEEGER Ø10	1
20	FX100205	LOWER BEARING SUPPORT	1
21	TO700135	BEARING 6900-2Z	1
22	VTCE 3X14	FAST TCEI M3X14	1
23	GIVEN AM3	M3 SELF-LOCKING NUT	1
24	FX100100	LEFT CARTER	1
25	FX100110	CARTER RIGHT	1
26	FX100115	SET VITI CARTER FENIX	1

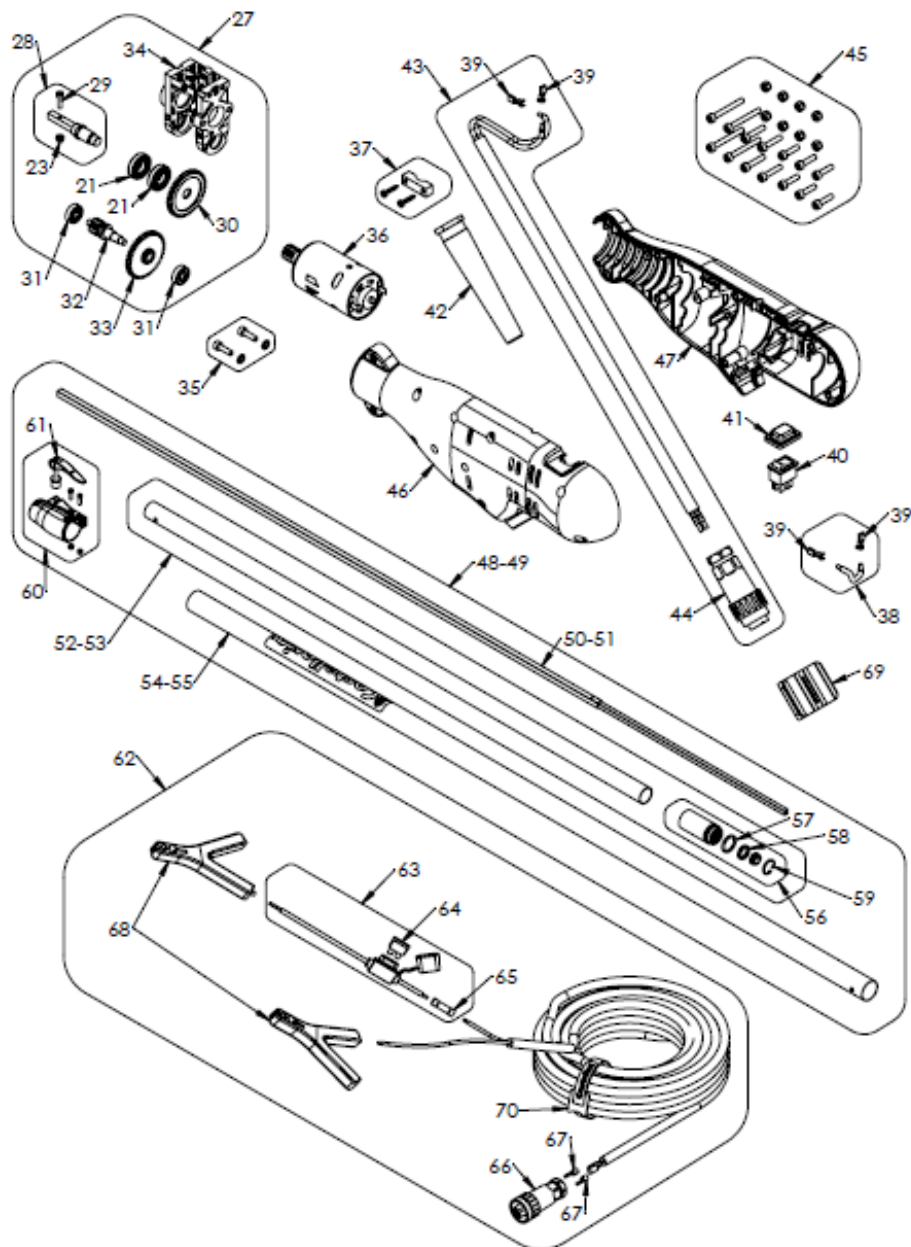

FENIX L/C V2 REV05 - 11/03/2021

21	TO700135	BEARING 6900-2Z	1
23	GIVEN AM3	M3 SELF-LOCKING NUT	1
27	TO900200	CHASSIS SET COMPLETE WITH GEARS	1
28	TO800205	TRANSMISSION SHAFT SET	1
29	VTCE 3X12	FAST TCEI M3X12	1
30	TO800220	RIGHT CYLINDRICAL CROWN	1
31	OE300130	BEARING 625 ZZ	1
32	TO800225	CYLINDRICAL PINION	1
33	TO800215	LEFT CYLINDRICAL CROWN	1
34	TO800210	HANDLE FRAME	1
35	OE300105	MOTOR SCREW SET	1
36	TO800200	ENGINE SET	1
37	OE400110	CABLE LOCK SET	1
38	TO800202	CABLE WITH 2 FASTONS	1
39	OE600203	FASTON 4.8X0.5 STRAIGHT FEMALE	1
40	OE400115	SWITCH 12A	1
41	OE600200	SWITCH PROTECTION SHELL	1
42	OE400141	PASSACAVO	1
43	TO800300	EXTERNAL CABLE 0.50MT	1
44	OE600116	SPINA FRUIT	1
45	TO800130	HANDLE SCREW SET	1
46	TO800101	CARTER LEFT HANDLE 2018	1
47	TO800106	CARTER RIGHT HANDLE 2018	1
48	ATK180	THIS COMPLETE TELESCOPIC 1,8-2,4MT	1
49	ATK230	THIS TELESCOPICA COMPLETE 2,3-3,3MT	1
50	TO900116C	FULL SHORT TRANSMISSION SET	1
51	TO900116	COMPLETE LONG TRANSMISSION SET	1
52	ATK180S	SHORT ROD SET Ø28	1
53	ATK230S	SET THIS LUNGA Ø28	1
54	TO900225	CARBON Ø35 SHORT ROD SET	1
55	TO900220	Ø35 LONG CARBON ROD SET	1
56	TO900127	BUSHING SET	1
57	OR4087	GASKET OR4087 21.82X3.53	1
58	TO900120	BEARING 6703-ZZ	1
59	TO700255	SEEGER Ø23	1
60	OE500100	SET LOCK SYSTEM	1
61	OE500106	QUICK CLOSE SET	1
62	OE800150	EXTERNAL CABLE 15 MT WITH 32V BLADE FUSE	1
63	OE800151	2015/2016 BULK CARRIER SET FOR 15 MT CABLE	1
64	TO800150	BLADE FUSE 32V 15 A	1
65	TO800239	PRE-ISOLATED HEAD CONNECTOR	1
66	OE600111	TAKEN FRUIT	1
67	TO800241	CAPOCORDA PUNTALINO 4/6	1
68	OE800152	START PLIERS SET	1
69	FX100325	FERRITE	1
70	OE800153	FELT BAND	1

REV05-11/03/2021

1.4 Specify components

1. rake
2. Comb support
3. Transmission body
4. Lock system
5. That telescopic
6. Motor body
7. switch
8. Cable with connector (0.50 m)
9. Cable with connector (15 m)
10. Fuse holder
11. Crocodile clamps for battery (12 V)

Short telescopic rod from 1.8 to 2.4 m.

Telescopic rod 2.3 to 3.3 m long.

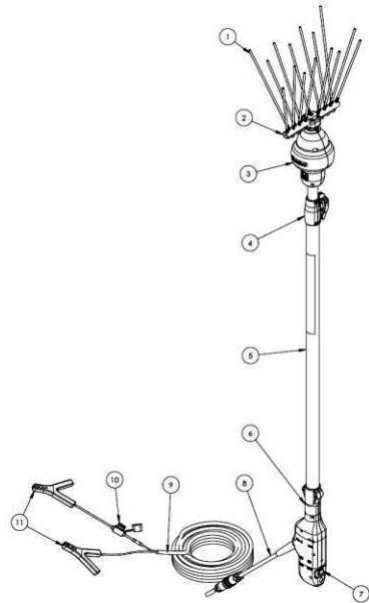

2. SAFETY AND PREVENTION

It is very important to read this manual carefully in order to be able to minimize the risks due to a reckless or incorrect use of the machine covered by the manual.

The user will have to instruct the operator on the risks due to the use of the machine, on the devices prepared for safety and on the general safety rules provided for by the directives and legislation of the country of use of the machine.

2.1. Safety signals (pictograms)

The dangerous situations related to the use of the machine are indicated in the manual using the following symbol:



The same symbol is used on the machine to highlight potential residual risks which, despite the adoption of all possible safety standards in the construction of the machine, it has not been possible to eliminate completely for certain conditions of use.

N.B.: It is important to keep the signals on the machine always clean and therefore clearly visible in order to allow users a quick identification of possible risk situations during use.

The staff undertakes to:

- always use the personal means of protection provided for in the legislation and follow the information in this manual,
- comply with all the indications of danger and caution indicated on the machine,
- do not perform operations or interventions on the machine on your own initiative that are not within your competence,
- report to your superior any problem or dangerous situation that may arise.
- The machine should only be used for the use for which it was designed.
- The machine must not be operated with the protections dismantled: the safety barriers and the crankses must not be removed or disengaged.



NB: Avoid wearing loose, fluttering clothes as they may get entangled in moving parts of the machine. It is important to use suitable clothing. The operator must not carry scissors or pointed tools in the pockets. Mention should be made of the prohibition of transit and parking within range of the machine outside the operator.

2.2. Safety in use and maintenance

2.2.1. Safety in use

- Before putting the machine into operation, make sure that all the safety is perfectly safe.
- The area in which the machine is used is to be considered a "Danger Zone", i.e. an area in the vicinity of which the presence of an exposed person poses a risk to the health and safety of that person. This is particularly the case in the case of the presence of persons not trained in the use of the machine.
- The area surrounding the operating area of the machine must always be cleaned and kept clear of any impediment. Make sure there are no people or animals in the machine's use area
- When a person is "exposed" or is in a "danger zone", the operator must immediately intervene by stopping the machine and possibly driving the person in question away.
- During the operation of the machine the operator must maintain a position that allows full control of the machine so that it can intervene at any time and for any eventuality.
- Always make sure that the power supply is detached before you leave control of the machine.
- Periodically check the integrity of the machine as a whole including protective equipment.

2.2.2. Maintenance safety

- Before carrying out any maintenance work on the machine, make sure that the power supply is detached.
- Maintenance operations must always be carried out by personnel qualified for these specific functions.

- At the end of maintenance and repair operations, before restarting the machine, the technical manager must ensure that the work is completed, the safety restored and that the protections have been reassembled.

During maintenance or repair operations, the use of suitable protective clothing such as:



Gloves



Otoprotective



Scile-proof shoes and anti crushing



Helmet

Adjustments, whether disengaged or without a crankcase, must be made by a single operator; during these operations, access to the machine to non-workers is prohibited. Avoid dust deposits on the machine, especially on the electric motor and suction filters.



NB: Do not direct water jets against the machine (e.g. for cleaning), they may generate short circuit!

2.3. Ecology and pollution

2.3.1 Waste management

The use and maintenance of the machine generates waste products that must be disposed of in compliance with the laws in force in the country where the machine is used. The user of the machine is required to comply with any recommendations of the manufacturers regarding the use of the products for the normal operation, cleaning and maintenance of the machine. Any special waste must be disposed of by contacting specialized firms authorized for this purpose. Ensure the correct disposal of the waste through the request of the receipt of "disposal". In the event of dismantling of the machinery, see section 4.5.

2.3.2. User Policy



The crossed-out bin symbol on the equipment indicates that the product at the end of its useful life must be collected separately from other waste and cannot be disposed of like household waste.

The user who must/will want to get rid of this equipment may refer to a person authorized to collect and recover such equipment or, alternatively, contact the manufacturer of the equipment that manages its end of life and follow the system indicated by it to allow its separate collection. In case of disposal in a foreign country, contact the competent local authority.

Professional users will have to take care of agreeing on the disposal of the product at the end of their life. Also refer to the website www.registroaee.it

3. use

3.1 Handling and transport

The machine is easily transportable both in packed and free form. It is recommended to pay attention to overhead power lines when it is transported for its use.

3.2 Before use

Before commissioning the machine, the operator must have read and understood all parts of this manual and in particular what is stated in Chapter 2 on safety. Before using the machine for the first time:

- familiarize yourself with control devices and their functions,
- check that all machine components subject to wear or deterioration are in a healthy state,
- ensure that all security systems are intact and that the fixed crankcases are in the correct position.

3.3 connection

The machine must be connected exclusively to a well-charged battery of 12 Volts via the clamps present at the end of the supplied power cable.

How to connect clamps:

- connect the RED CLAMP to the battery at the + sign
- connect the BLACK CLAMP to the battery at the sign -



NB:

- Do not connect clamps to generators, car batteries, agricultural vehicles or other power groups that could generate potentially harmful current spikes for the machine.  use the machine in contact with water.

- Be sure to screw the screw rings of the machine and cable connection sockets firmly, to avoid movements on the contacts that would damage the operation of the sockets themselves

3.4 Use of the machine

The machine is started by means of the switch placed on the handle. Once started approach with the comb to the branch to shake. Pay attention to branches especially laden with fruits.

- Hold the machine firmly with both hands and always work in stable condition on the legs.

NB: Avoid touching moving parts of the machine in any way.

- To turn off the machine it is enough to return the switch to the opposite position to the power-on position.

In the event that the machine is temporarily unused, it is important to place it in a stable horizontal position in order to avoid risky falls.

Tips for use:

The wear of the mechanical and electronic components of the machine is closely related to the mode of use of the machine itself. Therefore avoid insisting on the branch to be shaken until determining the stop of the machine, this would result in a mechanical and thermal overload of the components. Try to limit these locks as much as possible, so you will extend the life of your tool!

In order to avoid dangerous overloads of effort that may cause damage to the comb, it is recommended to intersperse the shaking action with regular breaks in order not to solicit the tool beyond the standards for which it has been designed and tested.

It is not recommended to use low or deteriorated batteries

4 MAINTENANCE AND CLEANING

4.1 Routine maintenance

The long life of the machine and the lower operating cost depend on compliance with this standard.

Periodic checks to be carried out:

1. Every 80 hours of work it is advisable to lubricate with high adhesive grease the anti-rotation plugs on which the rotor works (n° 13 of the exploded)
2. At each harvest season it is recommended to disassemble the handle containing the motor and the gearbox to clean the interior of dirty or aged grease, blow the engine with clean compressed air from the residues of the brushes' charcoals, grease the gears and close the handle.

The reported intervention times are to be considered indicative and are defined considering normal conditions of use of the machine. They may vary according to the mode of use of the machine and in relation to the characteristics of the environment in which it is used, e.g. humidity level, air cleaning (presence of dust). In conditions of heavy use, it is necessary to increase the number of maintenance work. Before proceeding with any operation, make sure that the machine is turned off and the clamps disconnected from the battery.

NB: Once the comb has been assembled, make sure before operation that the comb is disassembled correctly, following the assembly instructions chapter "4.2. and disassembly combs."

4.2 Comb assembly and disassembly

The machine is shipped with the combs disassembled. To mount, align the markings on the rotor and comb and follow the following images.

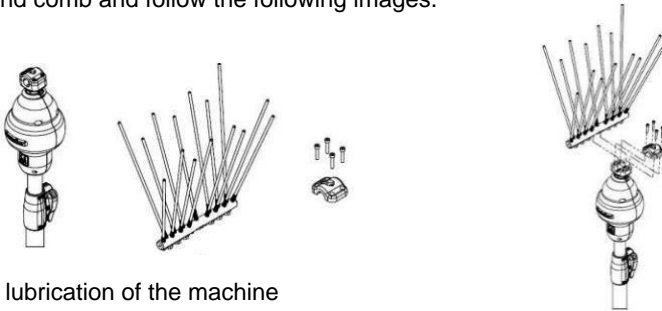

Cleaning and lubrication of the machine

The machine must be cleaned at the end of the season in order to avoid deposits of solid particles and dusts that can limit the efficiency of operation of the mechanical parts.

4.3 Set-aside

In the event that a long rest period of the machinery is specified, the following operations must be carried out:

- disconnect the machine from the power supply;
- clean the machine freeing it from any residues of dirt deposited on its surface and inside it, between the mechanical parts;
- carry out a check by replacing the damaged/worn parts from use; cover the machine to avoid the deposit of dirt dust on its surface and inside it.

Carrying out the maintenance operations described above carefully involves finding the machine in optimal operating conditions when the work resumes.

4.4 Disposal of the machine

Disconnect the machine from the power supply and cut the connecting cable. The machine consists of materials that can be recovered; in particular, iron recovery is possible. Deliver your dismissed machine to an official materials recycling center. Actively contribute to the protection of the environment by applying methods of elimination and recovery also in relation to the packaging materials with which the packaging of the machine is made. Your local authority will be able to inform you about the most effective ways and possibilities for disposing of the old instrument in an environmentally friendly manner.

4.5 Solving common problems – see website www.castellarisrl.com

problem ORIGIN OF THE PROBLEM	THE COMB DOES NOT START	COMB FREEZES DURING WORK	THE COMB WORKS SLOWLY
CHECK THE SAFETY FUSE	*	*	
LOW BATTERY CHARGE LEVEL			*

4.6 Spare parts

In order to guarantee the safety and long life of the product, it is recommended to use original spare parts exclusively. It is recommended to have specialist shelters or maintenance operations carried out by specialized and authorized personnel.

5 WARRANTY CONDITIONS

The manufacturer guarantees the new factory product for a period of 12 (twelve months) from the date of purchase.

NB: Check, at the time of purchase, that the machine is intact and complete in its components. Any complaints must be submitted within 7 days of receipt of the machine. The warranty involves the free repair or replacement of those parts that are defective.

NB: Replacements or repairs of the warranty parts do not in any way imply an extension of the warranty period. The buyer will only be able to assert his rights if he has complied with the conditions relating to the performance of the guarantee.

5.1 Exclusion from warranty

The warranty lapses in the following cases:

- There is a manoeuvring error attributable to the operator,
- The damage is due to insufficient or incorrect maintenance,
- Damage caused by assembly of non-original parts or as a result of repairs carried out by the user without the consent of the manufacturer,
- If detailed instructions are not followed in this manual.

6 DECLARATION OF CONFORMITY

Directive 2006/42/EC of the European Parliament and of the Council.

I signed Castellari Enrico responsible for the production Castellari S.r.l., "Construction scissors for agriculture", Via Lasie 16/E - 40026 IMOLA (BO) ITALIA declare under my sole responsibility that the Fenix L-C V2 electric rake complies with the essential safety and health protection requirements required by Directive 2006/42/EC of the European Parliament and of the Council.

CERTIFICATE DI GARANZIA · WARRANT CERTIFICATE ·

The P O

Product Name · Product's name
 Product Njmbre · Ονομασία Προϊόντος
 Name produced

Anno di immatricolazione prodotto · Registration's year of the product
 Ano de matriculacion del producto · Έτος Καταχώρησης Του Προϊόντος Στο Μητρω
 Year of registration of the product

Date of purchase · Purchasing dates
 Date of purchase · Ημερομηνία Αγοράς
 Date achat

Castellari Srl guarantees its products against manufacturing defects for 1 year from the date of purchase. Submit/ship this coupon together with invoice/receipt in case of service request.
 Castellari Srl guarantees that its products are free from manufacturing defects for 1 year from the purchase date.
 Please, to request technical support, submit/send this form together with the invoice/receipt of purchase of the goods.

The company Castellari Srl guarantees its products against manufacturing defects for 1 year from the date of purchase.
 Present/send this coupon along with the invoice/receipt in case of requesting assistance.

Castellari Srl guarantees its products for manufacturing defects for 1 year from the date of purchase.

Present /send this coupon with the calendar/receipt in case you request support.

Castellari Srl guarantees its products against manufacturing defects for one year from the date of purchase. Present / delivered this coupon as well as the invoice / receipt in case of assistance request.

Dealer's stamp
 Dealer's stamp

Dealer Seal
 Sales Store Seal

NOTE.....

.....

.....

.....

.....

.....

.....

.....

.....

.....

.....

.....

.....

.....

.....

.....

.....

.....

.....

.....

.....

.....

.....

NOTE.....

.....
.....
.....
.....
.....
.....
.....
.....
.....
.....
.....
.....
.....
.....
.....
.....
.....
.....
.....
.....
.....
.....
.....
.....
.....

NOTE.....

.....

.....

.....

.....

.....

.....

.....

.....

.....

.....

.....

.....

.....

.....

.....

.....

.....

.....

.....

.....

.....

.....

.....



Via Lasie 16/E - 40026 IMOLA (Bo) Tel.
+39 0542.43659 - +39 0542 628142
Fax +39 0542.41448 - +39 0542 626930
www.castellarisrl.com - info@castellarisrl.com